

In the event of a leak of spill:

If, at any time, you suspect a spill or leak of oil to the environment, immediately contact your oil company, fire department, or regional DEP office for assistance. *Leaks or spills of ten (10) gallons or more must be reported to DEP within two (2) hours.*

To report a leak or spill, call your local fire department and **DEP on our 24 hour statewide emergency response number:**

888-304-1133

If you have general questions, please call the DEP regional office nearest you during regular business hours, or visit the agency's Web site: <http://www.mass.gov.us/dep/>.

DEP's regional office telephone numbers:

Western	(413) 784-1100
Central	(508) 792-7653
Northeast	(978) 694-3200
Southeast	(508) 946-2700

Additional information can be found on our website at <http://www.mass.gov/dep/cleanup>



*Prepared by the Massachusetts
Department of Environmental Protection
One Winter Street, Boston, MA 02108
Printed on recycled paper.*

Other related information:

Removing Your Underground Oil Tank, A Homeowner's Guide. (Massachusetts Department of Environmental Protection, Bureau of Waste Site Cleanup – July 1996)

A Guide for Oil Companies, Don't Wait for an Accident to Happen, Preventing Costly Spills During Heating Oil Deliveries. (Massachusetts Department of Environmental Protection, Bureau of Waste Site Cleanup – January 1999)

A Massachusetts Property Owner's Guide to Hiring a Licensed Site Professional. (Massachusetts Department of Environmental Protection, Bureau of Waste Site Cleanup – June 1997)

Helpful Web sites:

<http://www.mass.gov/dep/bwsc/pubs.htm>
<http://www.massoilheat.org>
<http://www.epa.gov>

Heating Oil Delivery Lines

A Homeowner's Guide to Preventing Leaks

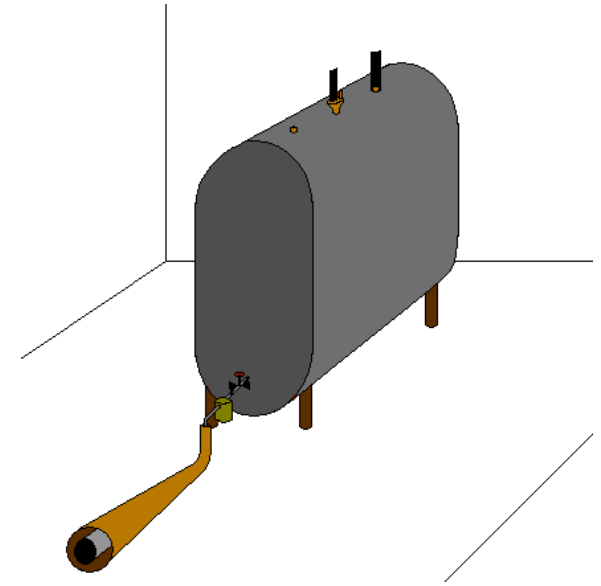

The Commonwealth of Massachusetts

Mitt Romney, *Governor*
Kerry Healey, *Lieutenant Governor*

Executive Office of Environmental Affairs

Ellen Roy Herzfelder, *Secretary*

Department of Environmental Protection

Robert W. Gollidge, Jr., *Commissioner*

Bureau of Waste Site Cleanup

Deirdre C. Menoyo, *Assistant Commissioner*

January 2001/rev. May 2004

In Massachusetts, home heating oil spills and leaks have become an all too common problem. The culprit in most cases is the delivery or supply line that carries home heating oil (#2 fuel oil) or kerosene (#1 fuel oil) from the storage tank to the furnace.

Why do home heating oil delivery lines leak?

Particularly in older homes, delivery lines are buried underground, or placed within or beneath concrete basement floors. They are generally made of copper, steel, brass or iron. When they come in direct contact with soil or concrete and water, the resulting chemical reactions can make them corrode and spring leaks. Delivery line breaks can also occur when there is shifting or settling in a home's foundation, basement floor, or the soil that supports them.

Regardless of how a leak happens, most of the resulting environmental and property damage could have been prevented had the homeowner simply encased the delivery line in a protective, non-metallic sleeve.

What is a delivery line protective sleeve and why should I care about my delivery line?

A protective sleeve is a non-metallic tube that encases the delivery line, protecting it from corrosion and physical damage. Since older delivery lines are neither visible nor encased, leaks can continue undetected for many years. A delivery line leak can seriously damage your property and lower its value.

When home heating oil leaks out of a buried delivery line, it initially migrates into the soil beneath the house and eventually may affect the groundwater. Drinking, breathing or coming in contact with contaminated water, air, or soil can be damaging to your health. Because of this, DEP regulations (found at 310 CMR 40.0000) require that oil leaks be cleaned up to certain standards within specific timelines. Such actions may include excavation of contaminated soil to protect public health and the environment.

Most homeowner insurance policies do not cover losses from leaking tank systems and environmental cleanups. You should check with your insurer to see whether or not your policy covers such losses. You should also consider checking into and joining an insurance and/or oil company program if you are not currently covered. Joining such a program could provide you with financial assistance and protection in the event of a leak or spill.

Paying a little now may save a lot later.

When home heating oil is lost through a buried delivery line, a couple of things are certain. First

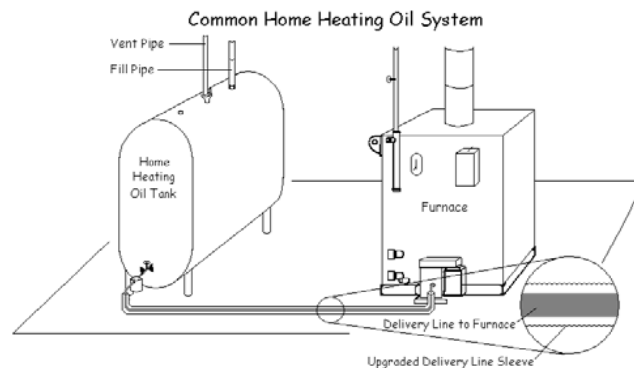

the cleanup will be expensive. Second, the experience will be highly disruptive to your family, and maybe your neighbors. Investing a small amount of money now by having your home heating oil delivery line encased in a protective sleeve can prevent leaks, sparing you the cost of cleanup and the potential loss of property value.

Is a delivery line protective sleeve required by law?

The State Board of Fire Prevention has come to recognize the environmental and health risks posed by buried unprotected heating oil delivery lines. State fire prevention regulations (found at 527 CMR 4.00) now require all new delivery lines to be encased in a non-metallic protective sleeve when installed. Sleeves are also required for replacement delivery lines when a listed oil safety valve is not used. Remember that if you own or purchase an older home, your delivery line may not have a protective sleeve since the original heating system may never have been upgraded.

What you can do:

Ask your oil burner technician to check your heating system and evaluate it for possible leaks. Inexpensive preventive measures such as the installation of an automatic shutoff valve or replacement of the oil delivery line with one encased in a protective sleeve can greatly reduce your risk of a heating oil leak.

For additional information and suggestions, contact your local fire department, oil company, or oil burner technician.